

Hinge with slotted holes

SUPER-technopolymer

MATERIAL

Glass-fibre reinforced polyamide based (PA) SUPER-technopolymer, black colour, matte finish.

ROTATING PIN

AISI 303 stainless steel.

STANDARD EXECUTION

Slots with pass-through hole for lowered cylindrical-head screws according to UNI 9327 that allow adjustment during fixing.

ROTATION ANGLE (APPROXIMATE VALUE)

Max 270° (-90° and +180° being 0° the condition where the two interconnected surfaces are on the same plane).

Do not exceed the rotation angle limit so as not to prejudice the hinge mechanical performance.

To choose the convenient type and the right number of hinges for your application, see the Guidelines (see page -).

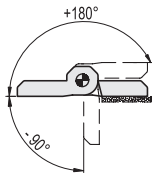

Resistance tests	AXIAL STRESS	RADIAL STRESS	90° ANGLED STRESS
Description	Max limit static load Sa [N]	Max limit static load Sr [N]	Max limit static load S90 [N]
CFM.60-SL-CH-6	960	1200	1360

The max static load is the value beyond which the material may break thus prejudicing the hinge performance. Obviously, a suitable coefficient must be applied to this value, according to the importance and the safety level of the specific application.

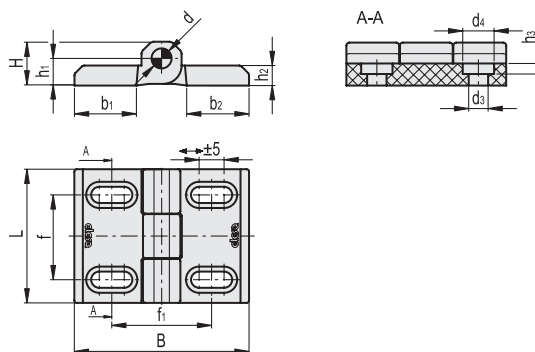

Code	Description	L	B	f±0.25	f1±0.25	H	h1	h2	h3	b1	b2	d	d3	d4	C# [Nm]	
425822	CFM.60-SL-CH-6	60	70	34	40	14.5	8	7.5	4	26	26	8	6.5	10.5	4	61

Suggested tightening torque for assembly screws.