

Adjustable handles

Technopolymer chrome-plated

LEVER BODY

Glass-fibre reinforced polyamide based (PA) technopolymer, chrome-plated, semi-glossy finish.

PUSH BUTTON

Black technopolymer, glossy finish.

STANDARD EXECUTION

Glass-fibre reinforced technopolymer clamping element with retaining pin, black colour, with knurling on the protruding part to make initial tightening easier. AISI 302 stainless steel return spring. Brass boss, tapped blind hole.

FEATURES AND APPLICATIONS

Particularly suitable when the lever turning angle is limited owing to lack of space.

Compared to other types of adjustable handles with metal retaining screw this solution offers:

- no visible steel parts subject to rust
- more comfortable lever release.

CHEMICAL AGENTS RESISTANCE

The chrome-plated surface is resistant to wear, scrapes and shocks. In laboratory tests carried out at ambient temperature (23°C), the chrome-plated surface revealed to be resistant to: sea water, detergents, acetone, ethyl alcohol, formic acid, chlorine solutions.

SPECIAL EXECUTIONS ON REQUEST

Bosses with different threadings.

INSTRUCTIONS OF USE

For clamping, lift the lever to disengage the clamping device teeth and bring it back to start position. By releasing the lever, the return spring automatically engages the teeth.

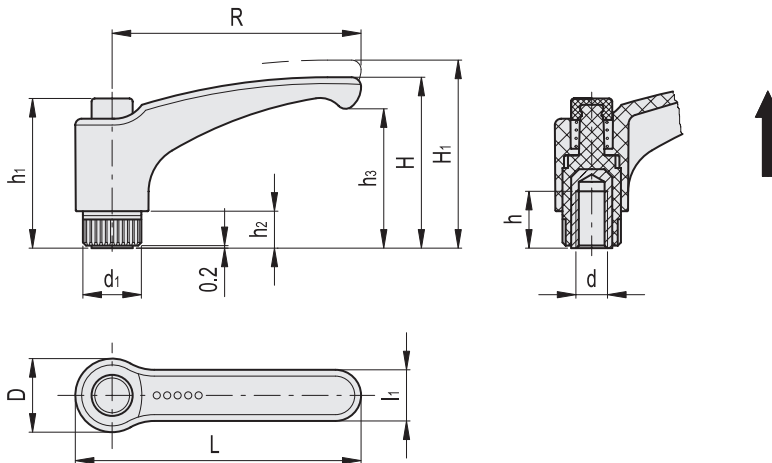

Code	Description	R	døH	L	D	H	H1	h	h1	h2	h3	d1	l1	Teeth no.	⚖️
152301	ERX.44-CR-B-M6	44	M6	52	15.5	32.5	36	10	29.5	6	25	12	11	18	10
152311	ERX.63-CR-B-M8	63	M8	73.5	19	43	47	13	37.5	8	34.5	15	13.5	20	20
152321	ERX.78-CR-B-M10	78	M10	90.5	24.5	54	58	18	47	12	44	19	16	24	44
152341	ERX.95-CR-B-M12	95	M12	109	26.5	64.5	69	20	54.5	13	53	21.5	18	26	51

