

Fluted grip knobs

Technopolymer, assembly with screws

MATERIAL

Polyamide based (PA) technopolymer, black colour, matte finish.

CLOSING CAP

Polypropylene based (PP) technopolymer, orange or black colour, glossy finish with matte central surface, snap-in mounting.

STANDARD EXECUTION

Assembly by means of hexagon head screws or standard lock nuts (not supplied) to put in place inside the knob by pressing.

SPECIAL EXECUTIONS ON REQUEST

On the surface of the closing cap words, marks, graphic symbols, etc... can be tampoprinted in colours.

ASSEMBLY INSTRUCTIONS

1. The base of the knob should rest on a flat surface.
2. Insert the screw or the lock nut into the knob hole by means of a thrust tool.
3. Push until the insert is completely fitted in.
4. Assemble the snap-in closing cap.



FAM design

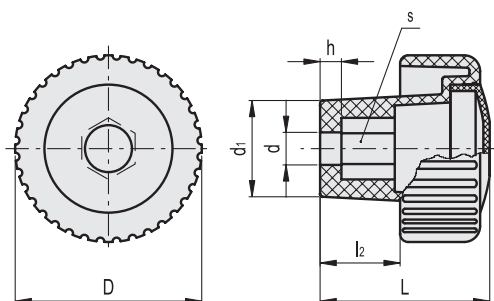

Code	Description	D	d	L	d1	l2	h	s	⚖️
138711	MCT.35 EH-5-C2	35	5	32	18	15	4	8	12
138712	MCT.35 EH-5-C9	35	5	32	18	15	4	8	12
138721	MCT.35 EH-6-C2	35	6	32	18	15	4	10	11
138722	MCT.35 EH-6-C9	35	6	32	18	15	4	10	11
138731	MCT.35 EH-8-C2	35	8	32	18	15	4	13	10
138732	MCT.35 EH-8-C9	35	8	32	18	15	4	13	10
138751	MCT.50 EH-6-C2	50	6	40	23	21	5	10	23
138752	MCT.50 EH-6-C9	50	6	40	23	21	5	10	23
138761	MCT.50 EH-8-C2	50	8	40	23	21	5	13	22
138762	MCT.50 EH-8-C9	50	8	40	23	21	5	13	22
138771	MCT.50 EH-10-C2	50	10	40	23	21	5	17	21
138772	MCT.50 EH-10-C9	50	10	40	23	21	5	17	21
138791	MCT.70 EH-8-C2	70	8	71	30.5	40	9	13	64
138792	MCT.70 EH-8-C9	70	8	71	30.5	40	9	13	64
138801	MCT.70 EH-10-C2	70	10	71	30.5	40	9	17	63
138802	MCT.70 EH-10-C9	70	10	71	30.5	40	9	17	63
138811	MCT.70 EH-12-C2	70	12	71	30.5	40	9	19	62
138812	MCT.70 EH-12-C9	70	12	71	30.5	40	9	19	62
138821	MCT.70 EH-14-C2	70	14	71	30.5	40	9	22	61
138822	MCT.70 EH-14-C9	70	14	71	30.5	40	9	22	61

RIGHT ASSEMBLY

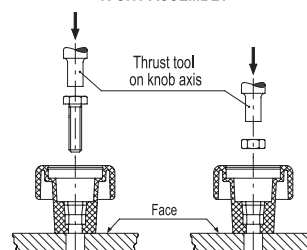

WRONG ASSEMBLY

