

Hinged joints with clamps

Technopolymer

CLAMPS

Glass-fibre reinforced polyamide based (PA) technopolymer, RAL 9005 (C9) black colour or grey RAL 7040 (C33) colour, matte finish.

SCREWS AND NUTS (SUPPLIED)

Cylindrical-head screw with hexagon socket in AISI 304 stainless steel with anti-seizure treatment.

Self-locking nuts in AISI 304 stainless steel.

STANDARD EXECUTIONS

- **TCC-AP-AP-T**: with teeth.
- **TCC-AP-AP-S**: without teeth.

FEATURES

Joints comprising clamps with external/internal teeth (36 teeth) have a 10° adjustment angle.

Joints comprising clamps without teeth can be positioned at any angle.

Clamps for tubes with a diameter of 30 ± 0.2 mm.

For smaller diameter tubes, the hole reduction sleeve can be used TCC-A (to be ordered separately).

The "s" grub screws may be replaced by the kit TCC-KS.

TECHNICAL DATA

The resistance values shown in the table were measured during laboratory tests at ambient temperature with the screws tightened to the suggested torque "C#".

ACCESSORIES ON REQUEST (TO BE ORDERED SEPARATELY)

- TCC-A: reduction sleeves.
- TCC-KS: clamping kit.
- GN 197: monitor mounts.
- TCC-KV: screws and clamping nuts.
- GN 990: connecting tubes.



ELESA Original design

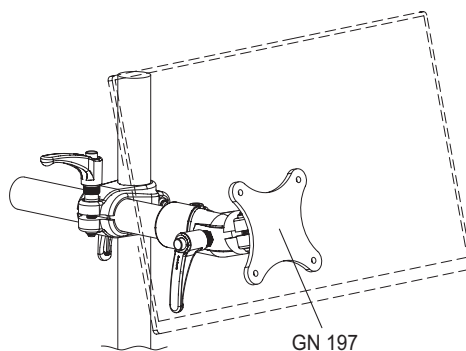
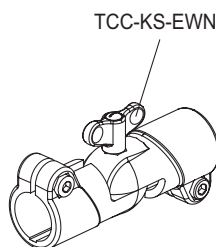
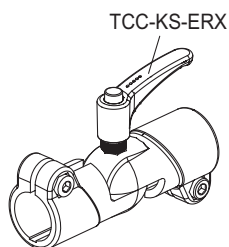

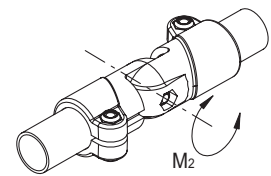
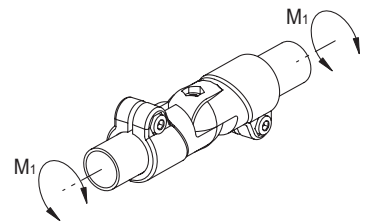
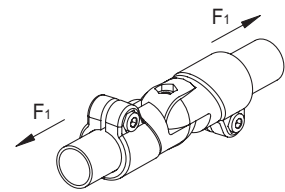
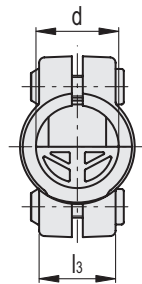
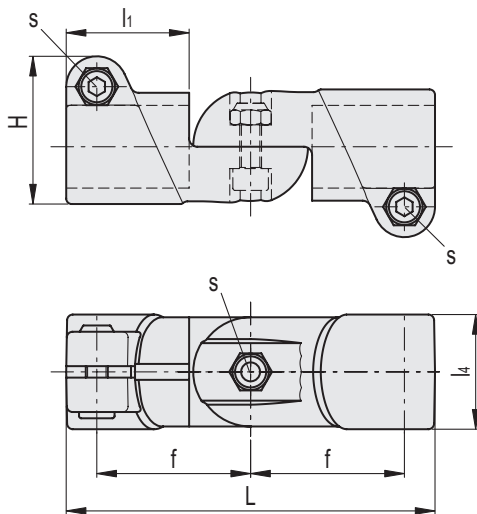

TCC-AP-AP-T

STAINLESS STEEL

Code	Description	d	L	H	f	l1	l3	l4	s	C# [Nm]	F1* [N]	M1** [Nm]	M2*** [Nm]	⚖
600801-C9	TCC-AP-AP-30-T-C9	30	135	54	56	45	28	42	M8	12	3300	33	140	178
600801-C33	TCC-AP-AP-30-T-C33	30	135	54	56	45	28	42	M8	12	3300	33	140	178

TCC-AP-AP-S

STAINLESS STEEL

Code	Description	d	L	H	f	l1	l3	l4	s	C# [Nm]	F1* [N]	M1** [Nm]	M2*** [Nm]	⚖
600802-C9	TCC-AP-AP-30-S-C9	30	135	54	56	45	28	42	M8	12	3300	33	6	178
600802-C33	TCC-AP-AP-30-S-C33	30	135	54	56	45	28	42	M8	12	3300	33	6	178

Suggested torque for screw assembly.

* Resistance to tube pull out

** Resistance to tube rotation

*** Resistance to joint rotation.

