

Three-arm knobs

Technopolymer

MATERIAL

Glass-fibre reinforced polyamide based (PA) technopolymer, black colour, matte finish.

VB.639/130: glass-fibre reinforced polypropylene based (PP) technopolymer, black colour, matte finish.

STANDARD EXECUTIONS

- **VB.639-A:** black-oxide steel boss, plain blind hole.
- **VB.639-B:** brass boss, threaded blind hole.
- **VB.639-FP:** brass boss, threaded pass-through hole.
- **VB.639-p:** zinc-plated steel threaded stud with chamfered flat end as in UNI 947 : ISO 4753 (see Technical data).
- **VB.639-SST:** AISI 303 stainless steel boss, threaded blind hole.
- **VB.639-FP-SST:** AISI 303 stainless steel, threaded pass-through hole.

APPLICATIONS

This knob has been designed for heavy duty work where the use of a hammer for a firmer clamping action is required.



ELESA Original design

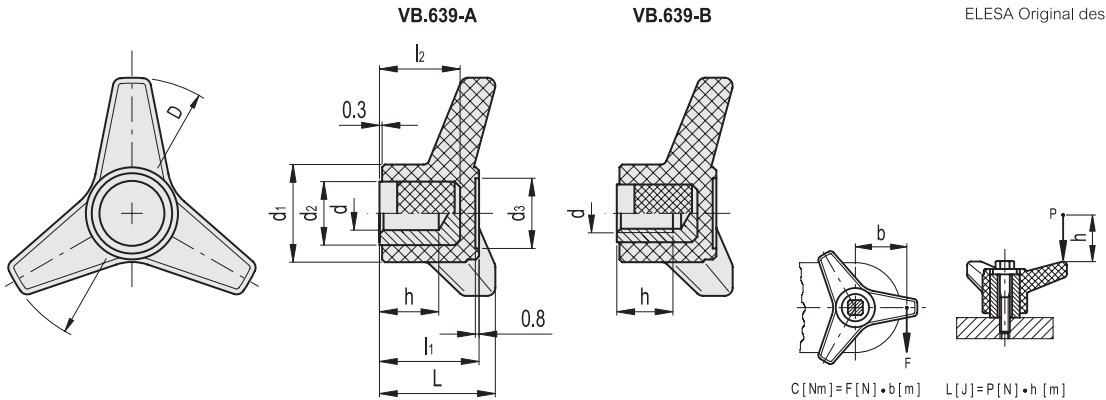

VB.639-A

Code	Description	D	dH9	L	d1	d2	d3	l1	l2	h	C# [Nm]	L* [J]	⚖
65531	VB.639/45 A-6	45	6	25	19	12	12	22.5	17	14	11	2	26
65631	VB.639/63 A-6	63	6	28	26	15	18	25	23	18	30	7	55
65672	VB.639/80 A-8	80	8	35	32	15	21	30	25	20	80	6	74
65702	VB.639/100 A-10	100	10	42	35	20	25	36	25	21	110	8	128
65742	VB.639/130 A-12	130	12	47	43	20	29	40	31	24	135	9	166

VB.639-B

Code	Description	D	d6H	L	d1	d3	l1	h	C# [Nm]	L* [J]	⚖
65541	VB.639/45 B-M6	45	M6	25	19	12	22.5	12	11	2	21
65545	VB.639/45 B-M8	45	M8	25	19	12	22.5	13	11	2	21
65635	VB.639/63 B-M8	63	M8	28	26	18	25	15	30	7	48
65636	VB.639/63 B-M10	63	M10	28	26	18	25	17	30	7	42
65674	VB.639/80 B-M8	80	M8	35	32	17	30	20	80	6	67
65675	VB.639/80 B-M10	80	M10	35	32	21	30	17	80	6	67
65676	VB.639/80 B-M12	80	M12	35	32	21	30	17	80	6	68
65705	VB.639/100 B-M12	100	M12	42	35	25	36	20	110	8	103
65706	VB.639/100 B-M14	100	M14	42	35	25	36	20	110	8	102
65745	VB.639/130 B-M16	130	M16	47	43	29	40	22	135	9	151

"Max limit Tightening torque" means the max torque value at which the metal insert, in normal conditions of use, is perfectly and strongly anchored to the plastic material.

* For impact strength (L) see Technical data.

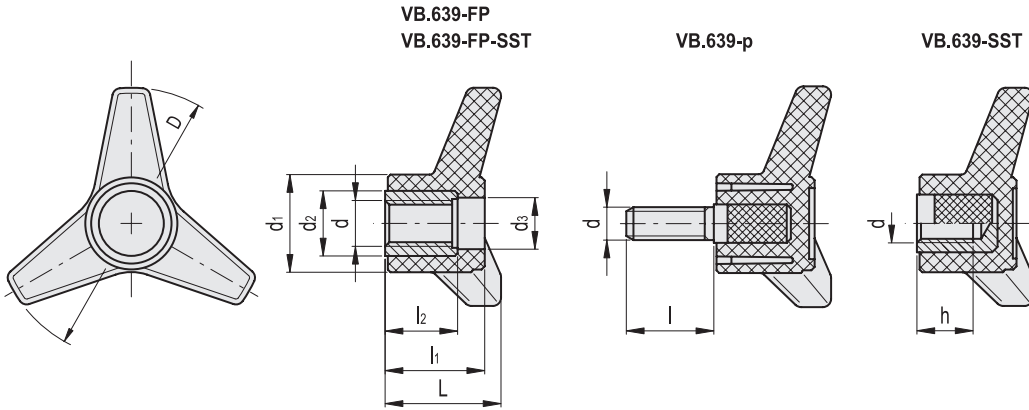

VB.639-FP

Code	Description	D	d _{6H}	L	d ₁	d ₂	d ₃	l ₁	l ₂	C# [Nm]	L* [J]	⚖
65551	VB.639/45 FP-M6	45	M6	25	19	8	9	22.5	12	11	2	17
65555	VB.639/45 FP-M8	45	M8	25	19	11	10	22.5	12	11	2	18
65641	VB.639/63 FP-M10	63	M10	28	27	16	13	25	21	30	7	49
65642	VB.639/63 FP-M12	63	M12	28	27	16	13	25	21	30	7	44
65680	VB.639/80-FP-M8	80	M8	35	32	18	17	30	25	80	7	77
65682	VB.639/80-FP-M10	80	M10	35	32	18	17	30	25	80	7	77
65681	VB.639/80 FP-M12	80	M12	35	32	18	17	30	25	80	7	77
65711	VB.639/100 FP-M16	100	M16	42	35	20	20	37	31	110	8	114
65751	VB.639/130 FP-M16	130	M16	47	43	24	22	40	34	135	9	172

VB.639-p

Code	Description	D	d _{6g}	L	d ₁	d ₃	l	l ₁	C# [Nm]	L* [J]	⚖
65561	VB.639/45 p-M6x20	45	M6	25	19	12	20	22.5	10	2	22
65565	VB.639/45 p-M8x25	45	M8	25	19	12	25	22.5	23	2	29
65652	VB.639/63 p-M8x25	63	M8	28	26	18	25	25	25	7	46
65692	VB.639/80 p-M10x30	80	M10	35	32	21	30	30	50	7	83
65722	VB.639/100 p-M12x40	100	M12	42	35	25	40	36	110	8	129

VB.639-SST

STAINLESS STEEL

Code	Description	D	d _{6H}	L	d ₁	d ₃	l ₁	h	C# [Nm]	L* [J]	⚖
65548	VB.639/45 SST-M6	45	M6	25	19	12	22.5	12	11	2	22
65638	VB.639/63-SST-M8	63	M8	28	26	18	25	15	30	7	47
65677	VB.639/80-SST-M8	80	M8	35	32	17	30	20	80	6	65
65678	VB.639/80-SST-M10	80	M10	35	32	21	30	17	80	6	65
65679	VB.639/80-SST-M12	80	M12	35	32	17	30	17	80	6	65
65708	VB.639/100-SST-M12	100	M12	42	35	25	36	20	110	8	91
65748	VB.639/130-SST-M16	130	M16	47	43	29	40	22	135	9	151

VB.639-FP-SST

STAINLESS STEEL

Code	Description	D	d _{6H}	L	d ₁	d ₂	d ₃	l ₁	l ₂	C# [Nm]	L* [J]	⚖
65685	VB.639/80-FP-SST-M8	80	M8	35	32	18	17	30	25	80	6	77
65686	VB.639/80-FP-SST-M10	80	M10	35	32	18	17	30	25	80	6	77
65687	VB.639/80-FP-SST-M12	80	M12	35	32	18	17	30	25	80	6	77

"Max limit Tightening torque" means the max torque value at which the metal insert, in normal conditions of use, is perfectly and strongly anchored to the plastic material.

* For impact strength (L) see Technical data.

